

May 2004

WOODCRAFT MATTERS

Editor : Gino Centofanti
Phone : 9432 4205
Fax : 9432 4206
e-mail: centraa@ozemail.com.au
Mail : 3 Lightwood Lane.
Plenty 3090

Contacts at Central Woodcraft

President

Robert McNamara 9876 1032

Treasurer

Stan Smith 9841 6557

Secretary

Anne Schaffer 9844 2072

Central Woodturners

Charlie Chamberlain 9728 2179

Templestowe Woodturners

Robert McNamara 9876 1032

Manningham Woodturners

Ian Hansford 9306 9875

Day Turners

John Tarry 9842 5324

Lady Turners

Anne Schaffer 9844 2072

Doncaster Carvers

Bryan Thompson 9459 4176

Doncaster Daycarvers – 1

Greg Williams 9723 3827

Doncaster Daycarvers – 2

Greg Williams 9723 3827

Doncaster Daycarvers – 3

Greg Williams 9723 3827

Remember

If you miss your normal meeting you are welcome to do a "make up" by attending another group that month. Just give the group leader a call to let them know you will be coming along.

Prez's Pout

Hello!!!! Hello!!!! Is anybody out there???? Can you hear (read) me????

It seems to have gone very quiet, maybe winter hibernation is setting in.

Recent attendances at some club meetings have been quite sparse.

I know, I know you all have private and/or corporate lives. So do we all!

Your leaders really need your support, and the best way to encourage them is to be there.

Sometimes we are not sure if our communication is getting through to you. Lets get a bit of feedback, positive, preferably.

The committee welcomed a new member at our last meeting, Yen Ip has joined us as another rep. for the carving groups, we look forward to his input to the club on your behalf.

The date has been set for our [Annual General Meeting on Wednesday, 28th. July, 2004, at 7.00pm.](#) at the clubrooms, when the usual excitement will be generated by the election of office bearers for the coming year, along with other titillating tidbits such as budgeting, Prez's report, where have we been, where do we go from here, etc., etc. Give us a big surprise, turn up!

The committee in discussing finances, are pleased to be able to contain the current fee structure for all groups, as well as make provision for more equipment acquisition next year, due largely to our excellent fund raising activities during the past year. (Be ready to renew your membership by the end of June)

We are currently purchasing a second industrial vacuum cleaner to assist with the cleaning duties, and having the filter replaced in the dust extraction system, which I'm sure many have noticed has been steadily losing it's effectiveness. (A special request regarding this system, please try to avoid off cuts or solid blocks of wood, as well as metal objects being sucked into the system, it contributes nothing for the longevity of the filter)

Uniform items are on hand for distribution. These should be available at your next scheduled meeting.

Thumbs up to all. Robert McNamara

RE-ENROLMENT FORM

Your Re-enrolment form, which you will receive shortly, will have a statement regarding the requirements of the Privacy Act. Nothing will change as far as the clubs use of your personal information. But to comply with our legal obligations, we require you to give us your permission to use your details.

Please read the statement and sign in the appropriate place.

Please contact me if you require any further clarification.

Robert McNamara club President ph 9876 1032

Nominations for Office-bearers

Extracted from the Constitution of Central Woodcraft at Manningham Inc.

23. (1) Nominations for candidates for election as officers of the Association or ordinary members of the committee shall be made to the Chairman at the Annual General Meeting provided consent of the candidate has been obtained.
- (2) If more than one nomination is received for a vacancy the result shall be determined by show of hands and the successful candidate will be the one receiving the greatest number of votes provided that where the vote is tied the result will be determined by lot.

All positions will be declared vacant at the A.G.M. Some members have declared their willingness to stand again. New blood is always welcome. Are you able to help?

WOODTURNERS WAFFLE

The May meeting saw 13 members attend and quite a few complete the activity run by Ian Hansford, a pair of skipping rope handles. It is easy to see that Ian is a quick learner no demo just Jack like drawings. Thanks for a good night Ian.

We also said farewell to Mal Carlson. Mal has been an active member of Central Woodcraft for quite a few years and not a bad bloke either, all the best to you and Val for the future, I hope we will hear from you when things settle down.

17th June meeting will be a bowl turning demonstration by our prize winning bowl turner Stuart Watson. If we have time I will demonstrate finishing with UBeaut products. This will be a full night so we must get started at 7.00pm. Bring a bowl blank approximately 200x50mm, small or thicker is OK 150x50mm minimum. Bring your tools, sand paper and finish. Show and tell will be bowls.

I have just finished 6 weeks box making with Ken. I have made three boxes, one small Vic ash, one jarrah and one myrtle. We are going on to do three more weeks to make box four. Mine will be blackwood with pin hinges. I would like to say how much I have enjoyed doing this course and appreciate all the work that Ken has had to do on the preparation.

I went to help with the Intro To Woodturning on the first night as Alan couldn't attend and Robert not able to turn. This made me think about the amount of work done by only three people. I go one night and do finishing and polishing and I love to see the happy faces when they see the finished bowl, but it is obvious more help is needed, even if you could help one or two nights.

Ken must have thought that Robert was a cut above him so decided to do something about it and have a go at his hand too. This is a warning to all to be careful whenever you are doing anything with power tools.

My spies tell me that a day turner has been very busy making things for the Mothers Day stall at Rolling Hills Primary School. These items were well received by the mums; you did a great job and gave me a rest this year.

Charlie Chamberlain

From the editor

I would like to express my gratitude to Alan McNaught from the **Wonthaggi Woodcrafters** for his contribution to this months newsletter.

I met Alan at his Grandson Chris' wedding of which I was a guest. It was a very pleasant evening indeed, Alan was explaining to me some of the things he'd been up to. We talked for quiet a while (Not like me at all !!!) and I asked if he would be interested in putting one of his ideas in writing for the newsletter.

So thanks again Alan, your efforts are very much appreciated.

If you are ever down this neck of woods I'd be happy to show you our club rooms.

Regards

Gino

TURNING AN ARC OF A CIRCLE BOWL.

I have turned many bowls using guesswork to determine the shape of the bowls, but recently I was given the challenge of making a bowl where the inside of the bowl is an exact arc of a circle.

By using the theorem of Pythagoras and a bit of algebra learnt at school over 60 years ago, I was able to work out what the radius of the circle should be.

The timber blank I had was 200mm in diameter and 60mm thick. The radius is determined by the formula –

$$R = (A^2 + B^2) / 2B$$

Where "R" is the radius to be determined,
 "A" is one half of the diameter of the blank, and
 "B" is the finished depth of the outside of the bowl. (**See fig. 1 On Page 5**)

In this case, "A" (half the diameter) is 100mm.
 "B" is 55mm. (5mm. Is allowed for the recess for the chuck)

Therefore: $R = (100^2 + 55^2) / (2 \times 55)$

Therefore: $R = 118.4\text{mm.}$

The external radius is therefore 118.4mm. If the thickness of the bowl is 5mm, the internal radius is 113.4mm.

After drawing a diagram on the side of a cereal box, I cut out two templates – one for the exterior of the bowl and one for the interior. On the exterior template I allowed for a rim for the bowl to rest on a recess for the chuck.

By using the templates, I was able to turn a bowl with an exact thickness of 5mm, with the inside of the bowl a perfect arc of a circle.

By Alan McNaught, **Wonthaggi Woodcrafters**

TURNING AN ELLIPTICAL BOWL

An ellipse is a curve such as the sums of the distances of each point in its periphery from two fixed points, the focus points, are equal.

To draw an ellipse, use a piece of string of a certain length so that the pencil will tighten the string against the two focus points as it draws the ellipse.

The Formula to determine the distance of the focus points from the center of the ellipse is –

$$F = \sqrt{A^2 - B^2}$$

Where “F” is the distance of the focus points from the center,
 “A” is one half of the diameter of the timber blank, and
 “B” is the ultimate depth of the outside of the bowl.

The length of string (L) is the sum of the diameter of the timber blank plus the distance between the two focus points – i.e.

$$L = 2A + 2F. \text{ (See fig. 2. On Page 5)}$$

If the timber blank is 200mm in diameter and 60mm thick, the ellipse can be determined as follows –

The distance of the focus points from the center is

$$F = \sqrt{100^2 - 55^2} \text{ (5mm has been allowed for the chuck recess)}$$

Therefore: $F = 83.5\text{mm.}$

The length of string required is

$$L = (2 \times 100) + (2 \times 83.5)$$

Therefore: $L = 377\text{mm.}$

By placing two tacks at the focus points, and having the string of the correct length, the ellipse can be drawn on a cereal box to indicate the external surface of the bowl. Allowance can be made for a rim at the base for the bowl to rest on and the recess for the chuck.

After cutting out a template for the exterior of the bowl, 5mm was cut off the other portion of the cereal box freehand to make the interior template.

The templates can then be used to make a perfect elliptical bowl. If this seems too much trouble, you can always make the bowl freehand so that it looks right.

By Alan McNaught, Wonthaggi Woodcrafters

$$R = \frac{A^2 + B^2}{2B}$$

Figure number 1

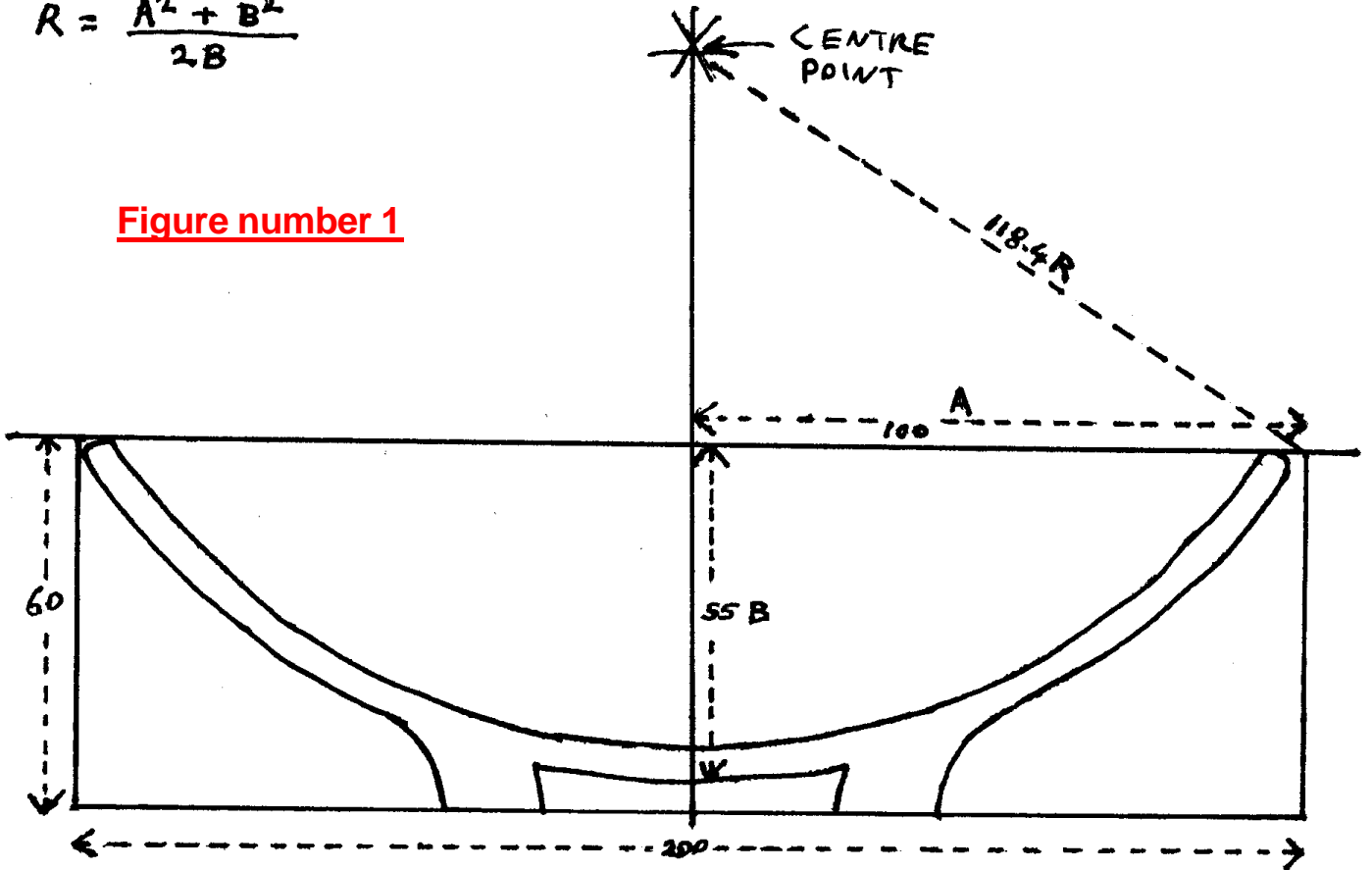

$$F = \sqrt{A^2 - B^2}$$

$$L = 2A + 2F$$

Figure number 2

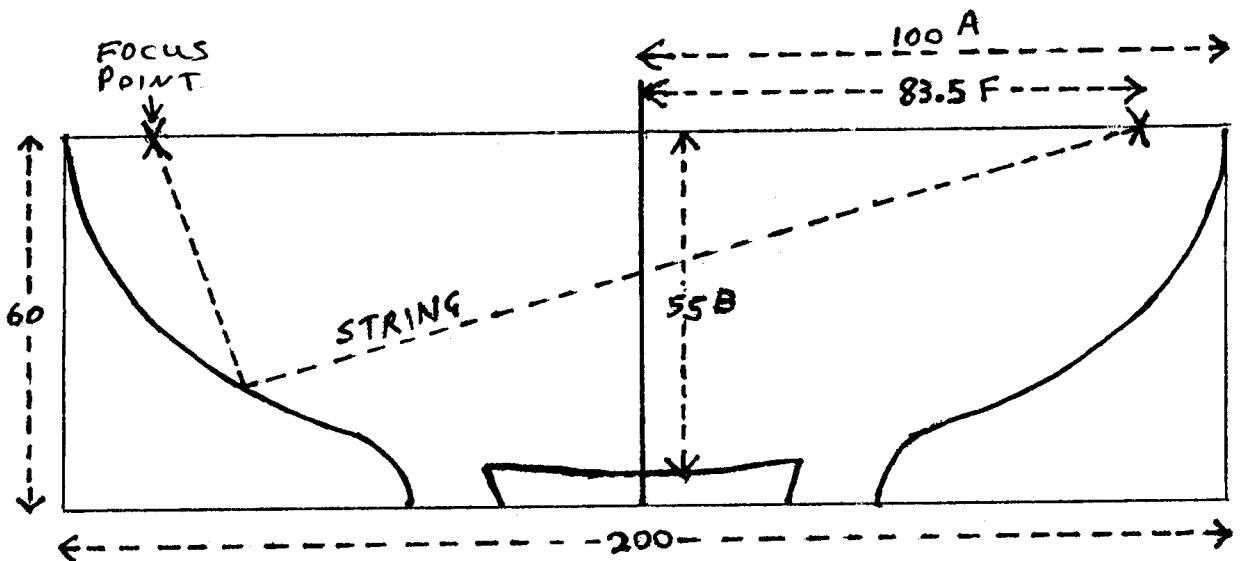

CARVE-IN 2004

To the sound of corellas and on a perfect May day Lady Northcote Recreation Camp at Rowsley came alive again on Friday 14th when some 55 wood carving devotees, including some supporting partners, sought out their lodges and bunkrooms before dividing into the work group of their choice. These were the noisy angle grinder carvers hacking into gums of every colour, carvers in the round working on eagles, the spoon makers, the relief carvers and the chip carvers. While the wood workers came from many different parts of the State it was pleasing to note that at least a quarter of them were from our club.

By 6pm dinner time, besides healthy appetites, there were lots of shavings and sawdust to testify to their efforts. Later that evening most of those present responded to the traditional "Show and Tell" speaking of their recent efforts and displaying an item on the central table which was soon weighed down with a diverse collection of sculptured wooden items, even two chairs and a wood vise. Bryan Thompson showed off the Central Woodcraft triangular show piece work in progress and vowed, with the help of Ian Elliot to get it substantially completed over the weekend.

By 9am Saturday they were all hard at it again. Things went well until one of ours [who shall be nameless] tested the emergency preparations by nicking two fingers and reporting to Doctor Charles who took him into Bacchus Marsh for fortunately only one stitch.

Saturday night there was something of an annual general meeting when some advance planning was done to ensure that the 2005 Carve-In [same time – same place] would go smoothly. Most present committed to be there and at least half paid in advance to be certain.

After packing and cleaning rooms there was another session before Sunday lunch followed by another "Show and Tell" this time, of the work produced over the three days. Some astonishingly good pieces were presented, spoken about and photographed. Before finally dispersing thanks were offered to all those who had done so much to make this weekend another success including the Kitchen staff, the tutors, the medical officer, and Bryan and his hard working committee.

By Derek Borrell

Royal Melbourne Show,

September 16th. to 26th, 2004

Members intending to exhibit items in the Art and Craft section of the show need to acquaint themselves with entry conditions, etc. and have entries in by the closing date of Friday 16th. July, 2004. Details on the notice board and in the schedule booklet in the attendance book. Entry form in the back of the schedule booklet can be photo copied, or from the RAS web site www.rasv.com.au

JOHN TALBOT

John Talbot's wife Ruby called a couple of nights ago to say that John has had a stroke. At the moment John is recovering at the Royal Talbot Hospital, at 1 Yarra Boulevard kew. Ruby said that John is in good spirits, visitors are welcome so if you want to visit please ring prior; so your visit doesn't correspond with John's therapy.

All the best to you John we are all hoping that you have a speedy recovery.

Regards from all of us.

BOX MAKING

I would like to thank Ken Morrison for volunteering his time and for putting in a massive effort in teaching all of the night class how to make boxes. It would have taken many hours of preparation on Ken's part not to mention the transporting back and forth of equipment during each session. While the course has officially come to an end, Ken has kindly extended it for a couple more weeks.

Once again thankyou for all your efforts.

Regards

Gino

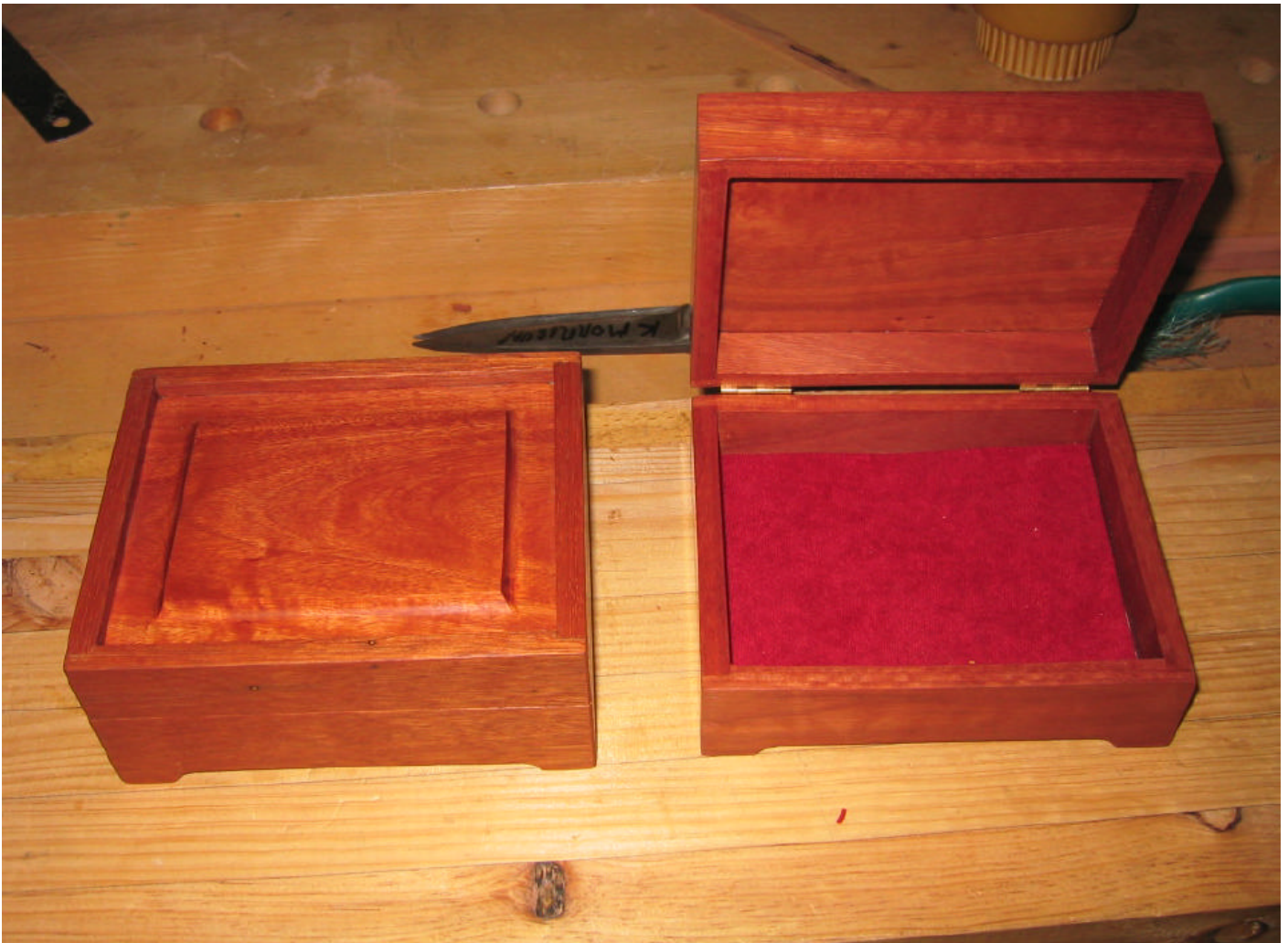

Photo above shows two identical boxes side by side made out of Red Gum. The open one shows the red felt used to line the bottom of the box. They were both assembled as a closed box and then latter put through the band saw, and sawn in half.

For this to work properly it is best to sand the inside bits of the timber prior to assembling.

Photo on left shows the hinges fitted to the above boxes.



These boxes were the first ones we made, as per the ones on page 7 they were also sawn open using the band saw. These boxes do not have hinges, the lid separates from the base when open.

These three boxes have different edge work, the one on the left made by myself has a square edge. The one in the middle has a routed shape on the lid, and the one on the right has a rounded edge top and bottom made by using a router.

The middle one and the one on the right were made by Bob and Ben from Maroodah Turners.



THE BLUE DIAMOND

23

THE VALUE OF UNDIES!

Re-printed from the Queensland Club's November Torque Tube

Be Careful what you wear (or don't wear) when working under your vehicle.....especially in public.

From the Sydney Morning Herald comes this story of a central west couple who drove their car to K-Mart only to have it break down in the parking lot. The man told his wife to carry on with the shopping while he fixed the car there in the lot.

The wife returned later to see a small group of people near the car, on closer inspection she saw a pair of male legs protruding from under the chassis. Although the man was in shorts, his lack of underpants turned private parts into glaringly public ones. Unable to stand the embarrassment she dutifully stepped forward, quickly put her hands UP his shorts and tucked everything back in place.

On regaining her feet she looked across the hood and found herself staring at her husband, who had been standing idly by. The mechanic however, had to have three stitches in his head.

